

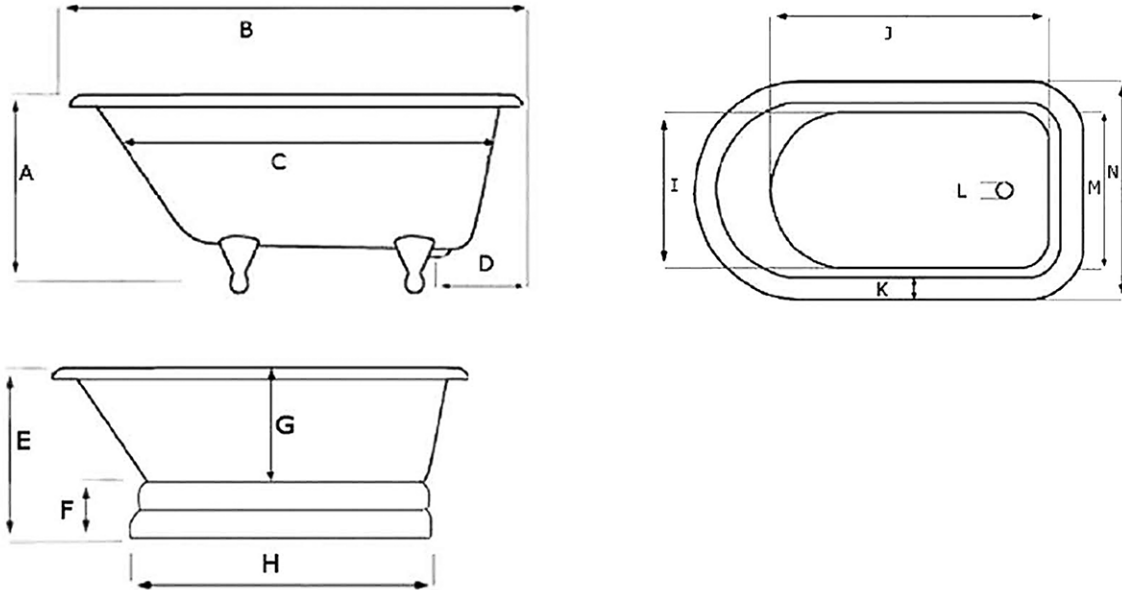

Roll Top Clawfoot BathTub by Randolph Morris

Cast Iron

TECHNICAL INFORMATION



DIMENSIONS (INCHES)

	A	B	C	D	E	F	G	H	I	J	K	L	M	N
48	23 ¹ / ₂	48 ¹ / ₂	42	11	-	-	-	-	18	30	3	1 ² / ₃	24	30
54	23 ¹ / ₂	54 ¹ / ₂	48	11	-	-	-	-	18	31	3	2 ¹ / ₅	24	30
57	23 ¹ / ₂	57	51	11	-	-	-	-	18	34	3	2 ¹ / ₅	24	30
60	23 ¹ / ₂	60 ¹ / ₂	54	11	-	-	-	-	18	35	3	2 ¹ / ₅	24	30
60*	-	60 ¹ / ₂	54	11	24 ¹ / ₂	6	17 ¹ / ₂	41	18	35	3	2 ¹ / ₅	24	30
67	23 ¹ / ₂	67	60	11	-	-	-	-	18	41	3	2 ¹ / ₅	24	30
72	23 ¹ / ₂	72	66	11	-	-	-	-	18	43	3	2 ¹ / ₅	24	30

DECK OR NO FAUCET DRILLINGS

WALL FAUCET DRILLINGS

	48	54	57	60	60*	67	72	48	54	57	60	60*	67	72
EMPTY (LB)	225	299	317	335	405	376	440	225	299	317	335	405	376	440
FILLED (LB)	534	641	709	785	855	926	1040	467	591	650	710	780	843	957
CAPACITY (GAL)	37	41	47	54	54	66	72	29	35	40	45	45	56	62
WATER DEPTH (IN)	12	13 ³ / ₅	13 ² / ₅	13 ² / ₅	13 ² / ₅	13 ² / ₅	13 ² / ₅	10 ¹ / ₂	11 ² / ₅	11 ² / ₅	11 ² / ₅	11 ² / ₅	11 ² / ₅	11 ² / ₅

Approximate Measurements *Pedestal **Anti-slip available on all models

All products and specifications are subject to change without notice. Randolph Morris is not responsible for typographical and/or dimensional errors. Typographical errors are subject to correction.

Note: Rough-in dimensions may vary +/- 1/2" and are subject to change. No responsibility is assumed by Randolph Morris.