

# INSTALLATION INSTRUCTIONS

## Pressure Balancing Valve

### Valve Body No. I-684

#### as used with Shower Fittings

### Description

This valve is precision engineered to provide satisfactory performance provided it is installed and operated in accordance with our recommendations contained in these instructions. In order to fully enjoy the comfort, safety and the reliability of this valve, be certain to familiarize yourself with these instructions.

### Operation

The pressure balancing cartridge contained in this valve compensates for pressure fluctuations in the water supply system through a spool and sleeve pressure balancing mechanism. The outlet temperature will change by no more than a mere  $\pm 2^{\circ}\text{F}$  ( $1^{\circ}\text{C}$ ) with a 50% drop in either the hot or cold water pressure. Even if the coldwater pressure fails completely, the anti-scald design will reduce the flow rate to a safe level ensuring reliable protection against scalding. The built-in check valves prevent cross flow between the hot and cold supplies.

Illustration I

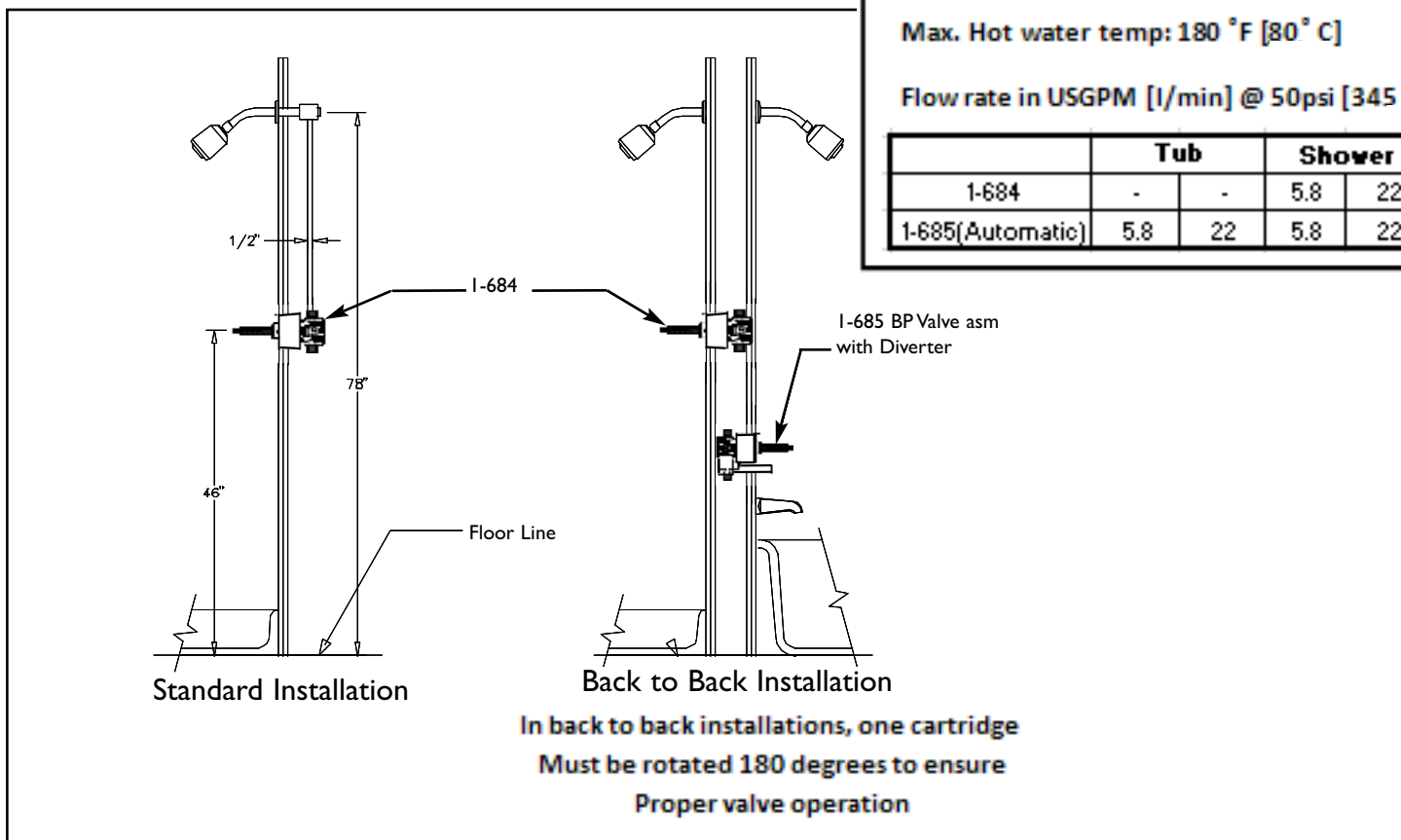

SPECIFICATIONS				
Min Operating pressure: 20 psi [140 KPa]				
Max. Operating pressure: 125psi [860 Kpa]				
Max. Burst pressure: 500 psi [3450Kpa]				
Max. Hot water temp: 180 °F [80° C]				
Flow rate in USGPM [l/min] @ 50psi [345 Kpa]				
	Tub		Shower	
1-684	-	-	5.8	22
1-685(Automatic)	5.8	22	5.8	22

### Before you begin

Make sure valve is securely fastened to studs. Be sure to remove trim items, handles, escutcheons and plates before installation. Wrap carefully and store until finished wall is completed.

Install the valve by positioning the 1/2" shower outlet in the up position. Finished wall must be within dimensions shown on the chart below.

On tiled wall surfaces, grouting must be either flush or raised for proper sealing of the cover plate.

**IMPORTANT:** It is not necessary to remove the cartridge from the valve during **NORMAL** soldering operations using propane-butane gas. **DO NOT USE OXYGEN-ACETYLENE.** When soldering CxC connections, do not solder within 4" of valve port. Open the stop valves when soldering inlets.

To test pipe joints, pressurize both hot and cold inlets.

### Installing Trim

Place cover plate on valve stem and slide into position. Install escutcheon/bonnet trim and mark the all-thread nipple, (Item 7) where excess needs to be trimmed.

Remove escutcheon/bonnet trim and cut all-thread nipple 1/16" less than indicated mark to prevent exposure of nipple threads. NOTE: Do not cut stem, (Item 6), or all-thread nipple until finished wall is complete and a dimension check of handle and escutcheons/bonnet trim is done. (Stem is grooved at 1/2" intervals) Cut stem at least 1/2" past the end of the cut all-thread nipple. Final stem length may vary based on individual handle base insertion. Reinstall escutcheon/bonnet trim and handle. Secure handle into place by tightening the handle setscrew or tightening the bonnet, depending on handle construction. Turn on water supply to check for leaks.

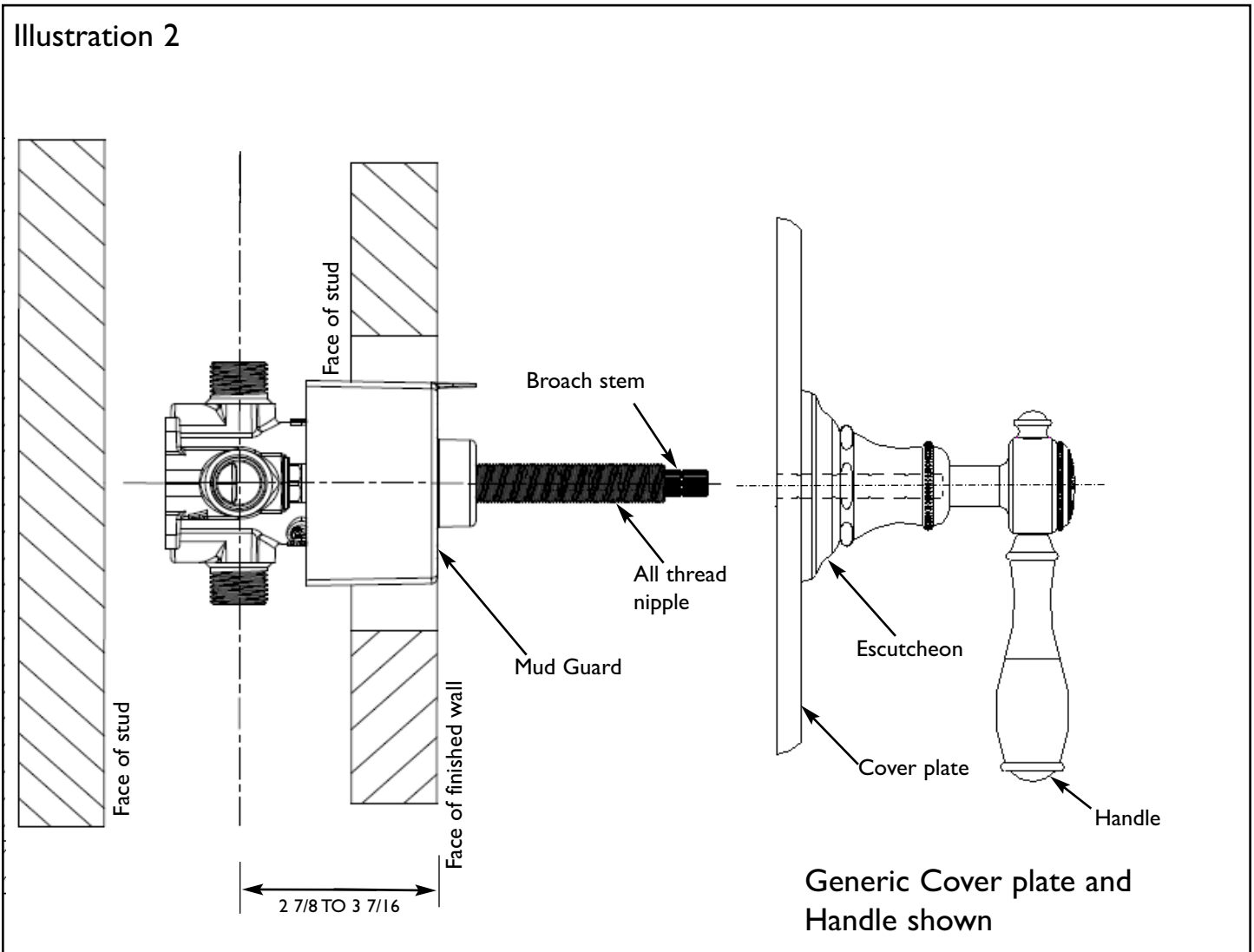

NOTE: Dimensions shown are from the inlet ports to the finished wall.

Illustration 3

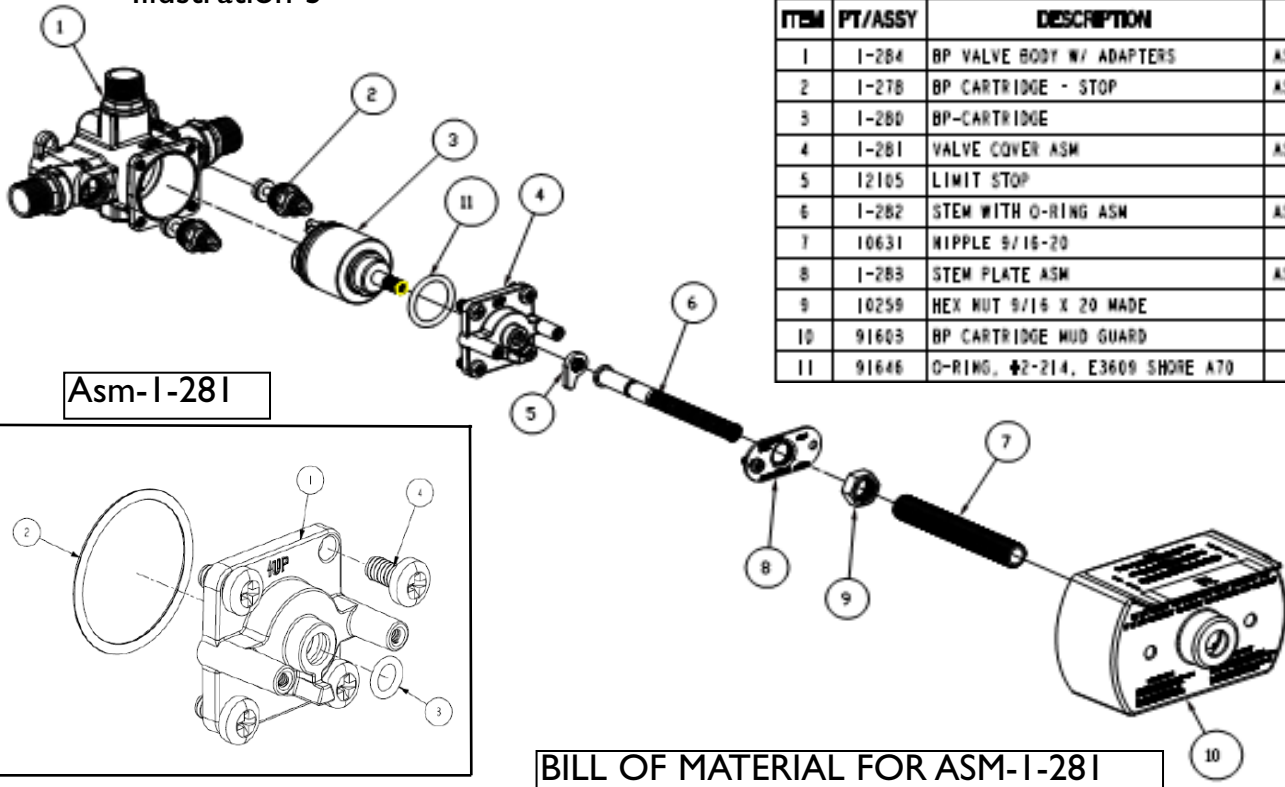

Asm-I-281

BILL OF MATERIAL (CURRENT LEVEL)

ITEM	PT/ASSY	DESCRIPTION	TYPE	QTY.
1	I-284	BP VALVE BODY W/ ADAPTERS	ASSEMBLY	1
2	I-278	BP CARTRIDGE - STOP	ASSEMBLY	2
3	I-280	BP-CARTRIDGE	PART	1
4	I-281	VALVE COVER ASM	ASSEMBLY	1
5	12105	LIMIT STOP	PART	1
6	I-282	STEM WITH O-RING ASM	ASSEMBLY	1
7	10631	NIPPLE 9/16-20	PART	1
8	I-283	STEM PLATE ASM	ASSEMBLY	1
9	10259	HEX NUT 9/16 X 20 MADE	PART	1
10	91603	BP CARTRIDGE MUD GUARD	PART	1
11	91646	O-RING, #2-214, E3609 SHORE A70	PART	1

BILL OF MATERIAL FOR ASM-I-281

ITEM	PT/ASSY	DESCRIPTION	TYPE	QTY.
1	12104	VALVE COVER	PART	1
2	91031	O-RING, #2- 129, EPDM EP7001, 65-75 DURO, NSF 61	PART	1
3	91650	O-RING, 2 X 7.5MM ID, S700BF, 65-75 DURO	PART	1
4	92244	SCRW, 1/4-20 X 1/2 PHL PAN HD SS	PART	4

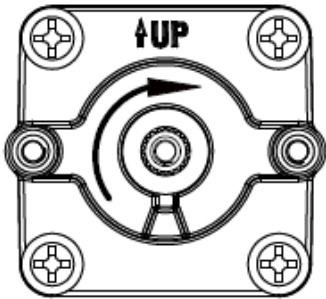

Illustration 4

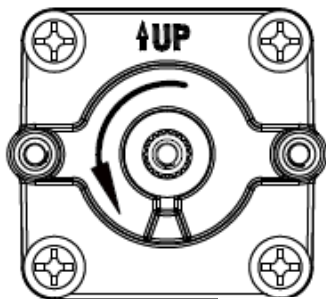

Illustration 5



LIMIT STOP HITS STOP BLOCK AT HIGHEST DESIRED TEMPERATURE

Illustration 6

### Setting the Temperature Limit Stop

This valve has an upper temperature limit stop, which can allow desired and safe hot water temperature (recommended maximum is 110°F). This stop may be adjusted once the valve is installed. Before making this adjustment, run water with the valve turned to the hot setting. If the water temperature is too high in this position, then perform the following adjustments:

1. Remove the trim (handle, escutcheon and cover).
2. Remove the all-thread nipple, (item 7), hex nut (item 9) and stem plate (item 8).
3. Remove the broach stem (item 6) and the limit stop (item 5).
4. Close the valve by turning the cartridge stem clockwise until it stops, (Illustration 4).
5. From the CLOSED position, rotate the cartridge stem counter-clockwise until the desired temperature is achieved. (Illustration 5).
6. Place the limit stop (item 5) on the cartridge stem against the stop block (Illustration 6). Rotate several times to make sure the stop is at the desired temperature setting.
7. Install the broach stem (item 6), stem plate (item 8), all thread nipple (item 7) and hex nut (item 9). (NOTE: For broach stem to be fully seated onto cartridge, the all thread nipple (item 7) and hex nut (item 9) must be tightly secured against the retaining plate).

\* **WARNING** - Never try to stop dripping by applying extreme force or overtightening the handle.

MALFUNCTION	CAUSE	REMEDY
Opening immediately to hot water.	Hot and cold water supplies have been connected in reverse.	Rotate cartridge 180 degrees.(Illustration 7)
Water drips after shutting off the valve.	Residual water in valve and piping.	Allow approximately 3-8 minutes to drain.*
Water leak from valve	O-ring seal on the inlet of the cartridge is faulty or seat assembly is damaged.	Check the O-ring & seat for cuts or overheating damage during installation. Replace if necessary.
Water insufficiently hot.	Adjustable handle position stop incorrectly set.	Refer to the instruction on "Setting Temperature Limit Stop".
Valve body too deep into wall.	The measured rough in or finished wall surface is incorrect.	Reset the valve.
Diverter will not stay on during shower.	Not enough backpressure between shower-head and diverter valve.	Ensure a 2.0GPM flow restrictor is mounted at the shower head.
No or low flow of hot or cold water.	Either the hot or cold side is not fully pressurized.	Verify that the service stops for both the hot and cold are fully open(turn counterclockwise) and pressurized (Illustration 8).
	Debris caught inside the inlet of the cartridge.	Remove the cartridge (See Page 3). If debris is lodged in the inlet of the cartridge The debris can be removed with a straightened paper clip or fine wire. Gently insert the wire and move it in a circular motion to dislodge any debris.

