



NPH

Paper Holder

Product Features

Easy Installation

Limited Lifetime Warranty

Solid Brass Construction

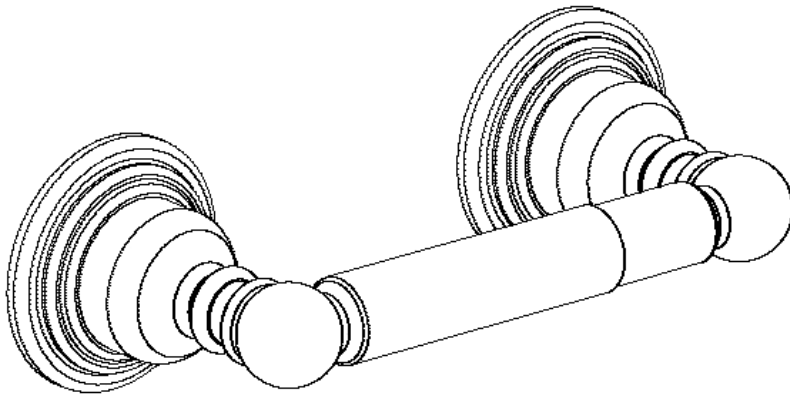

PRODUCT SPECIFICATION:

Paper Holder shall have brass construction and a limited lifetime warranty. Product shall be able to be installed easily. Product shall be Belle Forêt model NPH.

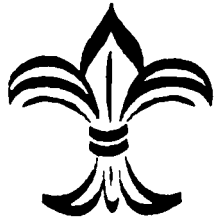

Belle Forêt
collection

NPH

Paper Holder

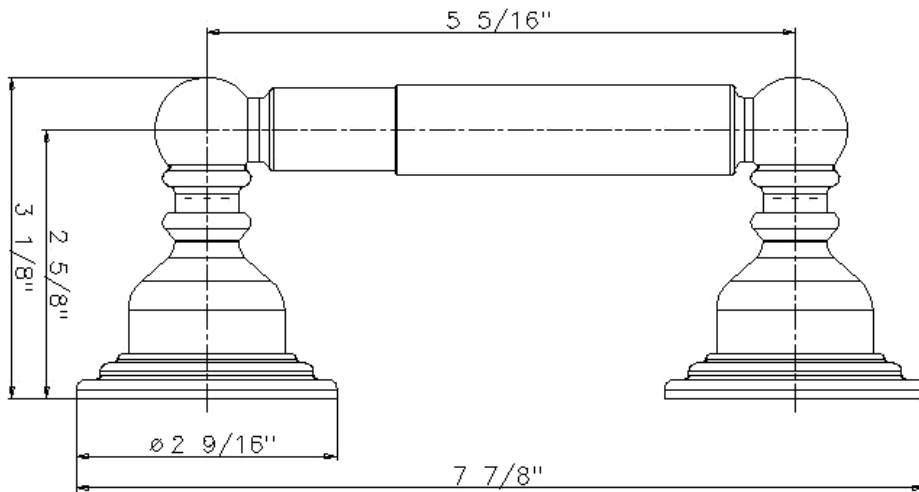

Available Finishes

Chrome

Polished Brass

Stainless Steel

Oil Rubbed Bronze

Matte Nickel